

Total No. of Questions—8]

[Total No. of Printed Pages—4+1

Seat No.	
-------------	--

**[5152]-537****S.E. (Elect./E&TC) (Second Semester) EXAMINATION, 2017****CONTROL SYSTEM****(2015 PATTERN)****Time : Two Hours****Maximum Marks : 50****N.B. :-** (i) Neat diagrams must be drawn wherever necessary.

(ii) Figures to the right indicate full marks.

(iii) Use of logarithmic tables, slide rule, Mollier charts, electronic pocket calculator and steam tables is allowed.

(iv) Assume suitable data, if necessary.

1. (A) Obtain the transfer function of system represented by the signal flow graph shown in figure no. 1. [6]

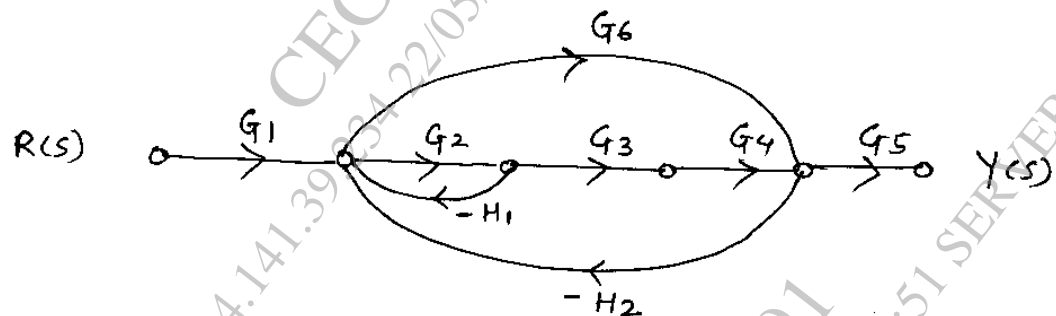

Fig. 1

- (B) For the system with closed loop transfer function

$$G(s) = \frac{25}{s^2 + 8s + 25}$$

determine damping factor, undamped natural frequency, rise time, peak time, peak overshoot and settling time with 2% tolerance band. [6]

P.T.O.

Or

2. (A) Obtain the transfer function of system represented by the block diagram shown in Figure No. 2. [6]

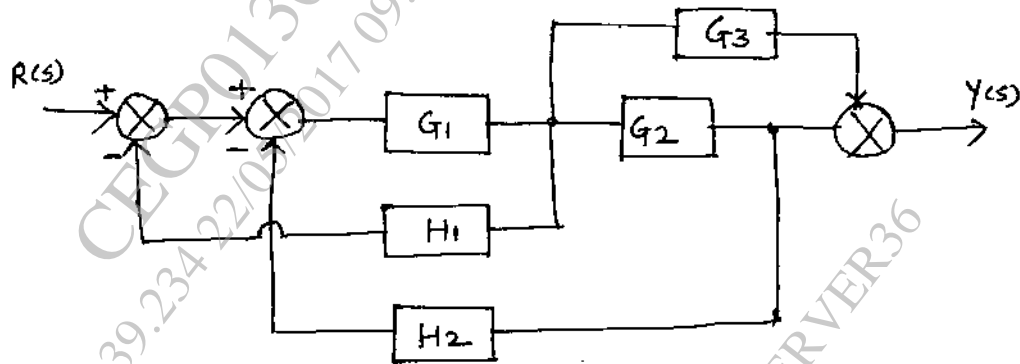

Fig. 2

- (B) For the unity feedback system with open loop transfer function

$$G(s) = \frac{100(s+2)}{s(s+5)(s+10)},$$

determine static error constants and steady state error if input is  $r(t) = 1 + t$ . [6]

3. (A) Investigate the stability of a system having closed loop characteristic equation : [4]

$$Q(s) = s^3 + 7s^2 + 10s + k = 0 \text{ and}$$

find  $K_{mar}$  and  $W_{mar}$ .

- (B) For the unity feedback system with open loop transfer function

$$G(s) = \frac{20}{s(s+1)(s+10)},$$

sketch Nyquist plot and investigate stability. [8]

Or

4. (A) Determine damping factor, undamped natural frequency, resonant peak and resonant frequency for the system with closed loop transfer function : [4]

$$G(s) = \frac{100}{s^2 + 10s + 100}.$$

- (B) Sketch root locus of a system with open loop transfer function

$$G(s) H(s) = \frac{K}{s(s+4)(s+6)}. \quad [8]$$

5. (A) Obtain controllable canonical and observable canonical state models for the system with transfer function :

$$G(s) = \frac{s^2 + 3s + 5}{s^3 + 5s^2 + 2s + 9}. \quad [6]$$

- (B) Investigate for complete state controllability and state observability of system with state space model matrices :

$$A = \begin{bmatrix} 0 & 1 & 0 \\ 0 & 0 & 1 \\ -5 & -1 & -2 \end{bmatrix}, \quad B = \begin{bmatrix} 0 \\ 0 \\ 1 \end{bmatrix}, \quad C = [1 \quad 0 \quad 2] \quad [7]$$

Or

6. (A) Derive formula of state transition matrix and state any *four* properties. [7]

- (B) Obtain physical variable state model of the system shown in Figure No. 3. [6]

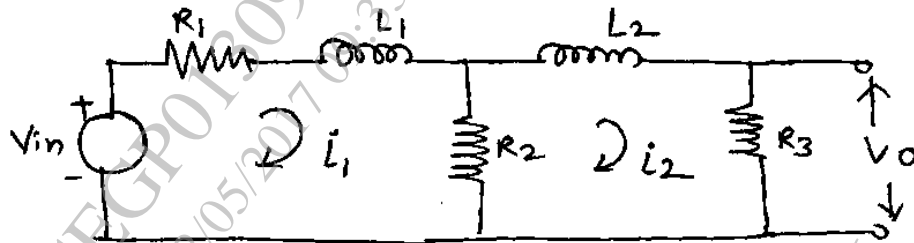

Fig. 3

7. (A) Determine pulse transfer function of a system shown in Figure No. 4, using first principle (starred Laplace transform) [7]

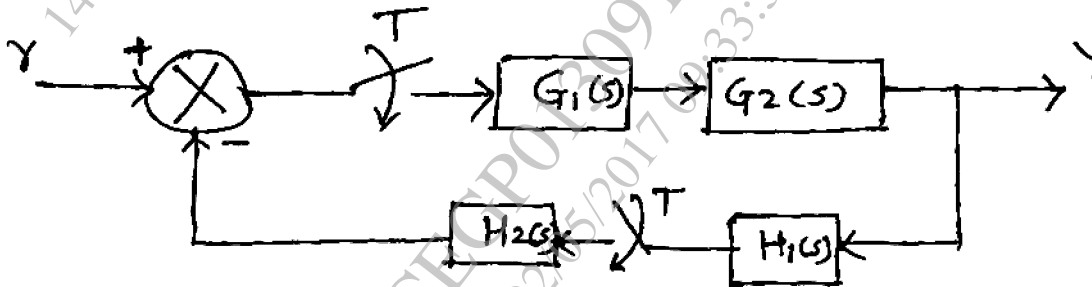

Fig. 4

- (B) Sketch step and ramp responses of P, PI & PID control actions. [6]

Or

8. (A) Determine pulse transfer function of a system shown in Figure No. 5. [7]

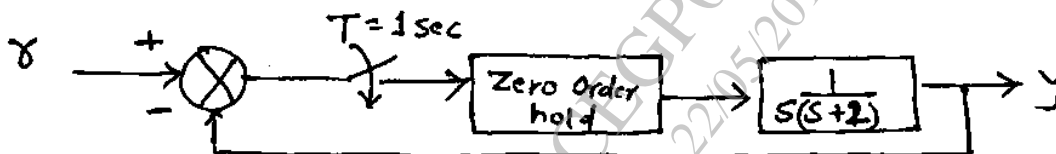

Fig. 5

- (B) Obtain ladder diagram for a 3-input two output system with boolean expressions : [6]

$$Y_1 = A \bar{B} C + A B \bar{C}$$

$$Y_2 = \bar{A} \bar{B} \bar{C} + A B$$

www.sppuonline.com