

Total No. of Questions—8]

[Total No. of Printed Pages—4

Seat No.	
-------------	--

[5667]-110

F.E. EXAMINATION, 2019
ENGINEERING GRAPHICS—I
(2015 PATTERN)

Time : Two Hours

Maximum Marks : 50

N.B. :- (i) Solve Q. 1 or Q. 2, Q. 3 or Q. 4, Q. 5 or Q. 6,
Q. 7 or Q. 8.

(ii) Use only half imperial size drawing sheet as answer book.

(iii) Retain all construction lines.

(iv) Assume suitable data, if necessary.

1. A line AB having its end point A is 15 mm above HP and 90 mm in front of VP, while point B is 50 mm above HP and 30 mm in front of VP. Draw the projections of the line if the projector distance between the point A and B is 80 mm. Find the Angle made by the line with HP and VP, Angle made of elevation line and plan line with HP and VP and true length, elevation length and plan length of the line. [12]

Or

2. A rectangular plate, 50 mm × 75 mm, is resting in HP on its smaller side. Its surface is inclined to HP at an angle of 40°, draw the projections, if its resting side is inclined to VP at an angle of 20°. Find the inclination made by the plane with VP. [12]

P.T.O.

3. A cube of 60 mm long edges held on one of its corners on HP in such a way that one of its solid diagonal is parallel to HP and perpendicular to the VP. Draw the projections of the cube. [13]

Or

4. (a) Construct a Parabola by using rectangular method having base length 100 mm and axis height 80 mm. [7]

(b) Draw the development of lateral surface for a hexagonal prism having a base edge 52 mm and axis height is 100 mm. [6]

5. Figure 1 shows a pictorial view of an object. Draw using first angle projection method. [13]

Draw :

(i) Sectional front view along the cutting plane line A-A

(ii) Top View

(iii) Left Hand Side View (LHSV).

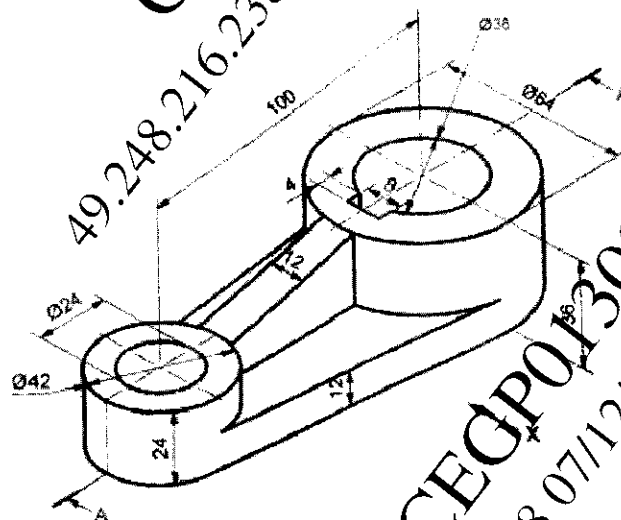

Figure 1

6. Figure 2, shows a pictorial view of an object. By using first angle projection method. [13]

Draw :

- (i) Front view in the X direction
- (ii) Top View
- (iii) Left Hand Side View (LHSV).

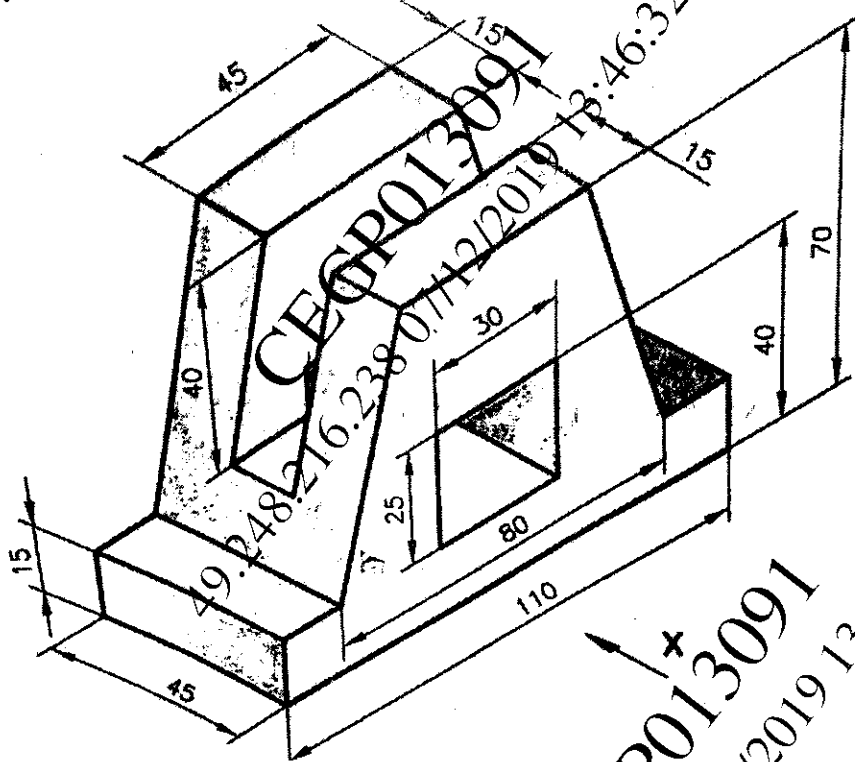

Figure 2

7. Figure 3 shows the Front view and Left hand side view of an object. Draw its Isometric view. [12]

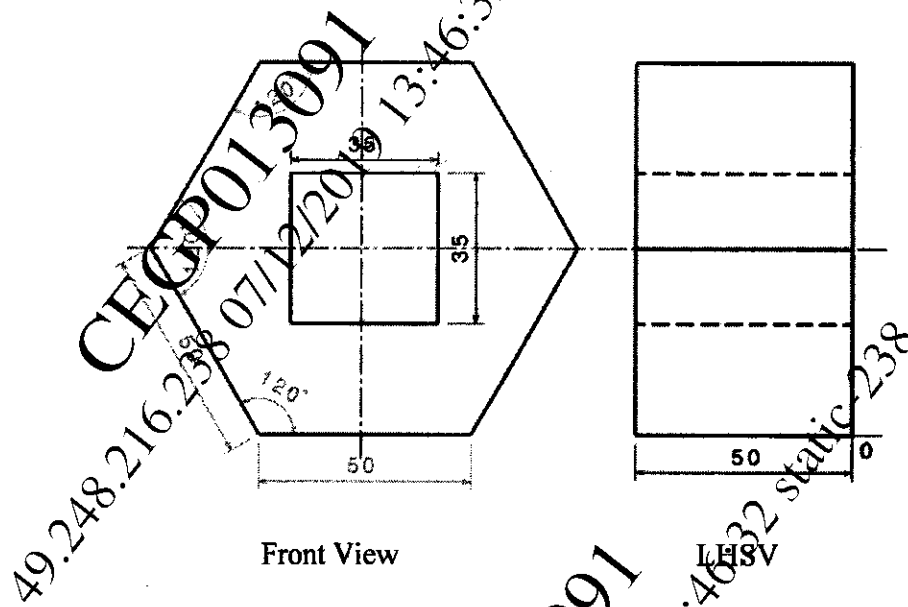

Figure 3

8. Figure 4 shows the Front view and Top view of an object. Draw its Isometric view. [12]

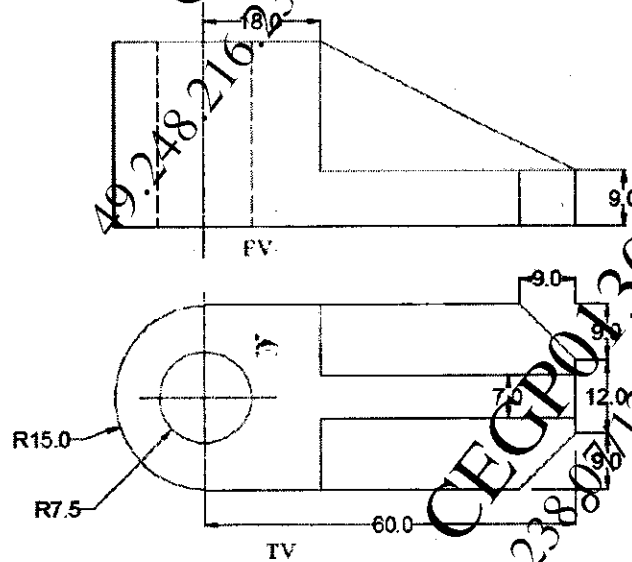

Figure 4