

Total No. of Questions : 10]

SEAT No. :

P4539

[Total No. of Pages : 5

[4959] - 1036

**B.E. (Mechanical Engineering) (Semester - I)**  
**RELIABILITY ENGINEERING (C) (Elective)**  
**(2012 Pattern)**

Time : 2½ Hours]

[Max. Marks : 70

Instructions to the candidates :-

- 1) All questions are compulsory i.e. Solve Q.1 or Q.2, Q.3 or Q.4, Q.5 or Q.6, Q.7 or Q.8, Q.9 or Q.10.
- 2) Figures to the right indicate full marks.
- 3) Assume suitable data, if necessary.
- 4) Use of electronic pocket calculator is allowed.
- 5) Neat diagrams must be drawn wherever necessary.

Q1) a) Define and explain in brief [4]

- i) Cumulative distribution Function
- ii) Failure Density

b) Define cut set and tie set. What is minimal set? Find the different minimal cut and tie sets for the system given in figure 1. [6]

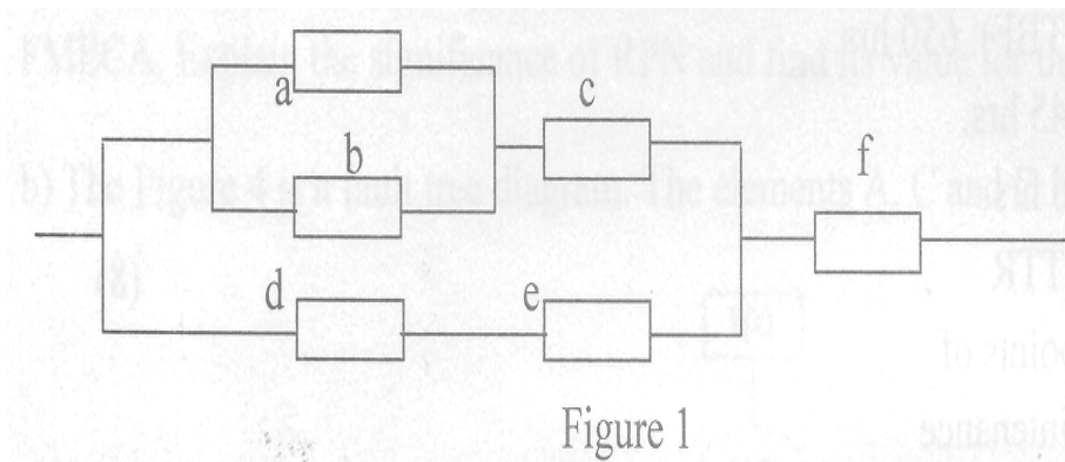

OR

P.T.O.

**Q2) a)** Explain in brief about mutually exclusive events with appropriate examples. [4]

b) The tests are conducted on 500 screws and the results are tabulated as given below. Find the failure density, hazard rate of the screws. [6]

Time interval (hrs)	0-10	10-20	20-30	30-40	40-50
Number of failed screws	174	126	85	75	40

**Q3) a)** Compare in tabulated format different probability distributions in detail. [4]

b) A system has the mission time is 200 hours & the system reliability required is 0.80. It consists of four subsystems A, B, C & D having failure rates 0.007, 0.004, 0.005 & 0.003 respectively per hour. Find the failure rate as well as reliability of each subsystem for the entire mission using ARINC method. [6]

OR

**Q4) a)** Explain different laws of probability with examples. [4]

b) The three main units connected in series together make an assembly of machine which requires reliability of 0.68. The individual reliabilities of units are 0.75, 0.84, 0.92 respectively. Explain and find how the reliability of machine should be apportioned among these units with minimum effort technique. [6]

**Q5) a)** A bearing is to be designed with a reliability value of 0.98 for an operation of 1200 hrs. Find the availability of a bearing over the same period of time if ratio of mean time to repair (MTTR) to mean time between failure (MTBF) is 0.3. Also find MTBF, MTTR, failure rate and mean repair rate assuming constant hazard for failure and repair. [8]

b) Explain:

i) Carderock model

ii) Design for maintainability [8]

OR

**Q6) a)** The following data is collected for a machine tool gear box. Find operational availability and inherent availability, the failure rate and mean repair rate assuming constant hazards for failure and repair.

Mean time between failures (MTBF): 650 hrs.

Mean time to repairs (MTTR) : 45 hrs.

Mean waiting time for repairs : 6 hrs.

Administrative time : 50% of MTTR [8]

**b)** Write down the salient points of

i) Reliability centred maintenance

ii) Technology aspect in reliability management [8]

**Q7) a)** Draw the fault tree diagram and calculate the reliability of the system represented by block diagram shown in figure 2. The reliability of each element is as given in the figure 2. [10]

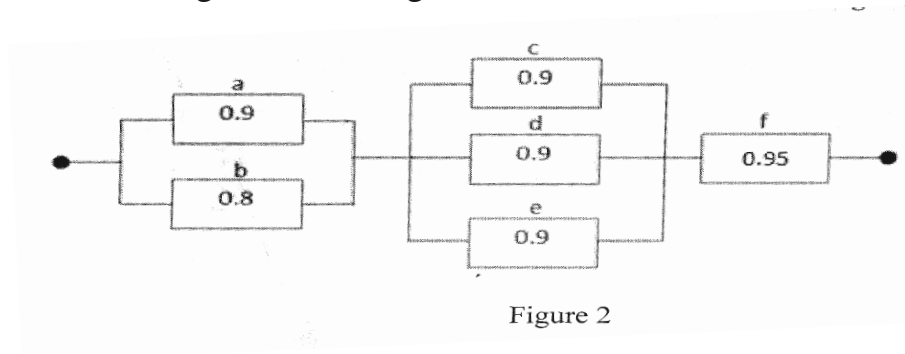

The figure 3 represents unit redundancy applied to the system in figure 2. Explain the reasons for unit redundancy and find the reliability of system shown in figure 3.

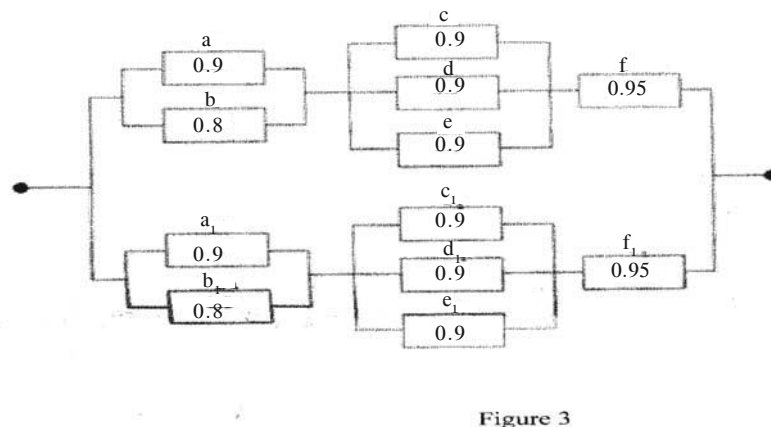

- b) Explain
- i) The methodology of constructing fault tree diagram.
  - ii) Taguchi method
- [8]

OR

**Q8) a)** Consider a case study for FMECA analysis and explain the steps involved in carrying FMECA. Explain the significance of RPN and find its value for the case study. [9]

b) The figure 4 is a fault tree diagram. The elements A, C and D have failure. [9]

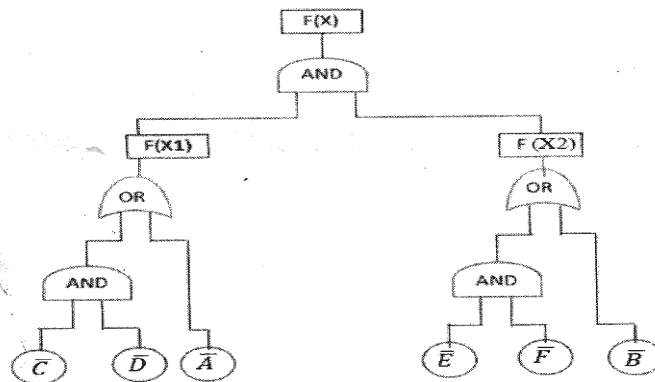

Figure 4

rates 0.002, 0.001 and 0.004 per hour respectively. The elements B, E and F have failure rates 0.001, 0.003 and 0.002 per hour respectively. Draw the block diagram of the system and find out the failure rate of the system.

**Q9) a)** Explain the Markov model. Explain in detail its application in reliability analysis of system having constant hazard rate. [8]

b) The following data is obtained while testing of a rubber gasket. [8]

Failure number	1	2	3	4	5	6	7	8	9
MTTF (hrs)	27	21	14	30	33	39	28	20	23

Plot the variation of reliability against time using

- i) Mean ranking method and
- ii) Median ranking method

OR

**Q10)a)** Write short notes on

- i) Load-strength interaction
  - ii) Reliability data acquisition and its graphical analysis [8]
- b) The stress developed in a crank shaft is known to be normally distributed with a mean stress of  $120 \text{ N/mm}^2$  and standard deviation of  $24 \text{ N/mm}^2$ . The mean material strength of crank shaft is  $245 \text{ N/mm}^2$  and standard deviation of  $39 \text{ N/mm}^2$ . Assuming that the material strength of crank shaft and induced stresses are independent, determine average factor of safety, minimum and maximum values of factor of safety. [8]

